

GMP24-370CA 24mm planetary gearbox plus 370 permanent magnet DC motor

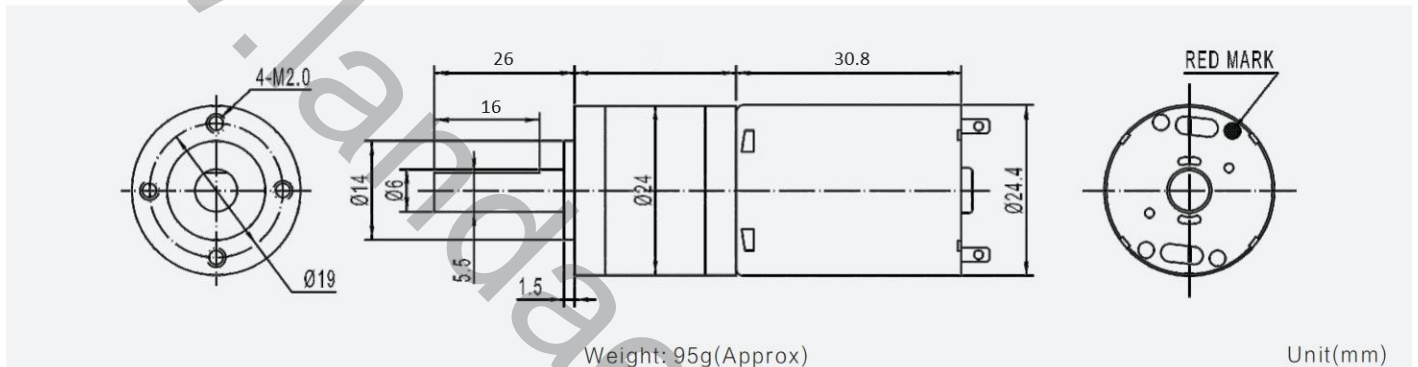

模数 Module	0.4			
额定负载 Rated torque (kg.cm)	5.0 kg.cm max			
瞬间允许力矩 Max momentary tolerance torque (kg.cm)	10.0 kg.cm max			
减速比 Reduction ratio	1/4	1/14 1/19 1/27	1/51, 1/71 1/100, 1/139	1/189, 1/264 1/369, 1/516 1/720
齿轮箱减速级数 Number of gear stages	1	2	3	4
减速箱长度 L (mm)	23	28	33	38



减速电机技术参数 Gear Motor Technical Data

减速比 Reduction ratio	19	27	51	71	100	139	189	264	369	516
6.0V 空载转速 No-load speed (rpm)	280	195	105	75	55	40	29	21	15	11
6.0V 负载转速 Rated speed (rpm)	250	180	95	68	48	35	25	18	13	9
6.0V 负载力矩 Rated torque (kg.cm)	0.3	0.5	0.7	1.0	1.4	2.0	2.5	3.5	4.4	5.0
12.0V 空载转速 No-load speed (rpm)	280	195	105	75	55	40	29	21	15	11 ★
12.0V 负载转速 Rated speed (rpm)	250	180	95	68	48	35	25	18	13	9 ★
12.0V 负载力矩 Rated torque (kg.cm)	0.3	0.5	0.7	1.0	1.4	2.0	2.5	3.5	4.4	5.0 ★

单电机技术参数 Motor Technical Data

电机型号 Motor model	额定电压 Rated voltage VDC	无负荷 No-load		额定 Rated			堵转 Stall		
		转速 Speed r/min	电流 Current mA	转速 Speed r/min	力矩 Torque g.cm	电流 Current mA	功率 Power W	力矩 Torque g.cm	电流 Current A
TRK-370CA-22170	6.0	5600	50	4870	25	320	1.25	191	2.1
TRK-370CA-15360	12.0	5600	25	4850	25	170	1.24	186	1.1

