

4611110028700

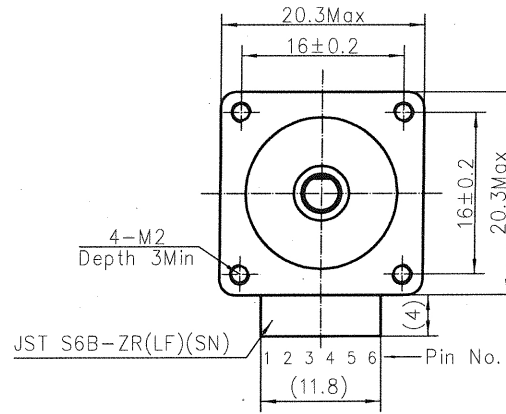

接线图
Wiring Diagram

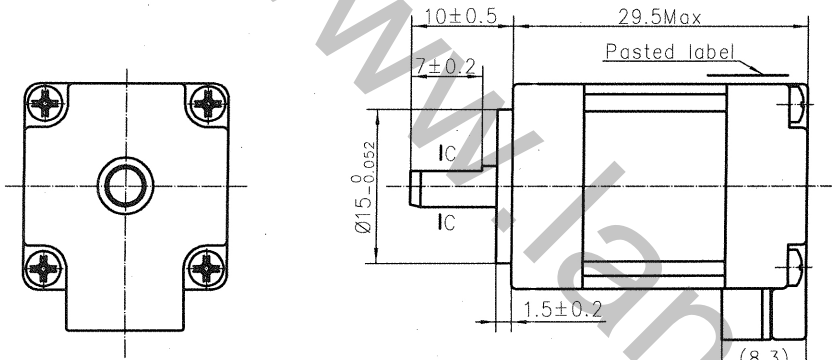
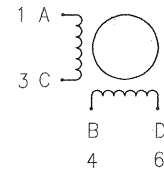

励磁顺序 vs. 旋转方向
Exciting Sequence vs. Direction of Rotation

STEP	A	B	C	D	CW
1	+	+	-	-	↑
2	-	+	+	-	
3	-	-	+	+	
4	+	-	-	+	

从安装面看为顺时针方向
Clockwise view from mounting side

规格 Specifications

1. 相数 Number of Phase	2
2. 步距角 Step Angle	1.8°
3. 额定电压 Rated Voltage	4.3V DC
4. 额定电流 Rated Current	0.5Amp
5. 保持力矩 Holding Torque	32mNm Typ.(Two phase on/rated current)
6. 相电阻 Phase Resistance	8.6ohm±10%(20°C)
7. 相电感 Phase Inductance	5.6mH±20%(1kHz 1V rms)
8. 转子惯量 Rotor Inertia	1.6gcm ²
9. 电机重量 Motor Weight	0.04kg
10. 绝缘等级 Insulation Class	B(130°C)

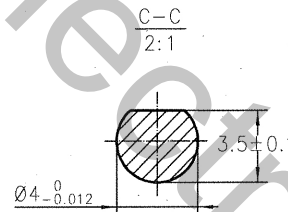

铭牌 Label Detail

MOONS' STEPPING MOTOR
TYPE MS08HY1P4050
XXXXXXXX YY/MM/DD

Work Order Date Format
加工单号 日期格式

Unit: mm
第一角画法
FIRST ANGLE METHOD
未注线性与角度尺寸公差
Tolerance for linear and angular dimensions without individual tolerance indications
GB/T 1804-m eqv ISO 2768-1: m
未注形状与位置尺寸公差
Geometrical tolerance for features without individual tolerance indications
GB/T 1184-K eqv ISO 2768-2: K

批准 Approve	
标准化 Standard	
工艺 Technology	
审核 Check	
设计 Design	
NAMES	SIGNATURE
DATE	DATE

MOONS' Hybrid Stepping Motor
Shanghai Moons' Electric Co., Ltd.

This document is released for information only. Its reproduction in whole or in part or its dissemination to third parties is prohibited. All trademarks and registered trademarks appearing on this document are the property of their respective owners.

REV.	版本记录 REVISION RECORD	DATE	UNLESS OTHERWISE SPECIFIED	MS08HY1P4050	Rev.A	SCALE 2:1	Sheet 1 of 1
------	----------------------	------	----------------------------	--------------	-------	-----------	--------------