

# MD5 Series

# 5-Phase Stepper Motor Driver

Small, light and high speed and torque 5-phase stepper motor driver

### ■ Features

- Bipolar constant pentagon drive method
- Includes Auto Current Down and self-diagnosis function
- Low speed rotation and high accuracy controlling with microstep-driving (Except for MD5-ND14)  
[Max. resolution - 250 division / In case of 5-phase stepper motor of which basic step angle is 0.72°, it enables to control up to 0.00288° per pulse and it requires 125,000 pulses per rotation.]
- Photocoupler input insulation method to minimize the effects from external noise



⚠ Please read "Caution for your safety" in operation manual before using.



(Except for MD5-HF14-AO, MD5-HD14, ND14)

### ■ Ordering information

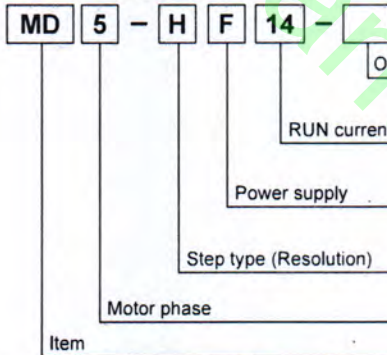

Output	No mark	Zero point excitation output*1
	AO	Alarm output
RUN current	14	1.4A/Phase
	28	2.8A/Phase
Power supply	D	20-35VDC
	F	100-220VAC
Step type (Resolution)	H	Micro step(250divisions)
	N	Normal Step
Motor phase	5	5-Phase
Item	MD	Motor Driver

※1: Except MD5-ND14

- ※KR-55MC can be replaced with MD5-HD14.
- ※KR-5MC can be replaced with MD5-ND14.
- ※MD5-MF14 can be replaced with MD5-HF14.
- ※KR-505G can be replaced with MD5-HF28.

### ■ Specifications

Model	MD5-HD14	MD5-HF14	MD5-HF14-AO	MD5-HF28	MD5-ND14
Power supply	20-35VDC 3A*1	100-220VAC 50/60Hz			20-35VDC 3A
RUN current	0.4 to 1.4A / Phase			1.0 to 2.8A / Phase	0.5 to 1.5A / Phase
RUN method	Bipolar constant pentagon drive				
Basic step angle	0.72° / Phase				
Resolution	1, 2, 4, 5, 8, 10, 16, 20, 25, 40, 50, 80, 100, 125, 200, 250 division (0.72° to 0.00288° / Phase)				1, 2 division (0.72°, 0.36° / Phase)
Input pulse width	Min. 0.5μs			0.1μs	Min. 10μs
Pulse Duty	50%				
Rising/Falling time	Max. 120ns			Max. 1μs	Max. 120ns
Max. input pulse frequency*2	1MHz			500kHz	50kHz
Input voltage level	High : 4-8VDC, Low : 0-0.5VDC				
Input resistance	270Ω(CW, CCW) 390Ω(HOLD OFF, DIVISION SELECTION)		270Ω(CW, CCW) 390Ω(HOLD OFF)	270Ω(CW, CCW) 390Ω(HOLD OFF, DIVISION SELECTION)	390Ω (CW, CCW, HOLD OFF)
Environment	Ambient temperature	0 to 40°C, storage: -20 to 60°C	0 to 50°C, storage: -10 to 60°C		0 to 40°C, storage: -20 to 60°C
	Ambient humidity	35 to 85%RH, storage: -10 to 90%RH	35 to 85%RH, storage: 35 to 85%RH		
Approval	CE	CE c UL US	CE	CE c UL US	CE
Unit weight	Approx. 220g	Approx. 660g	Approx. 650g	Approx. 1kg	Approx. 120g

※1: When using over 30VDC, it should be mounted at ventilated place due to increasing heat.

※2: Max. pull-out frequency and max. slewing frequency are variable depending on resolution, or load.

※Environment resistance is rated at no freezing of condensation.

- (A) Photo electric sensor
- (B) Fiber optic sensor
- (C) Door/Area sensor
- (D) Proximity sensor
- (E) Pressure sensor
- (F) Rotary encoder
- (G) Connector/Socket
- (H) Temp. controller
- (I) SSR/Power controller
- (J) Counter
- (K) Timer
- (L) Panel meter
- (M) Tachol/Speed/ Pulse meter
- (N) Display unit
- (O) Sensor controller
- (P) Switching mode power supply
- (Q) Stepper motor& Driver&Controller
- (R) Graphic/Logic panel
- (S) Field network device
- (T) Software
- (U) Other

# MD5 Series

## 5-Phase stepper motor driver [MD5-ND14]

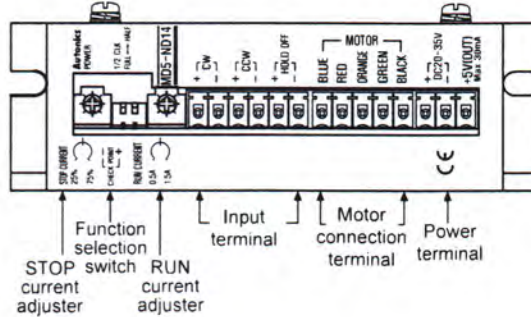

### Function selection switch



NO	Name	Function	Switch position	
			ON	OFF
1	1/2 CLK	Pulse input method	1 Pulse input	2 Pulse input
2	FULL ↔ HALF	Resolution Setting	0.72°	0.36°

#### • 1/2 CLK

※ 1/2 CLK switch is to select pulse input mode.

※ 1-pulse input mode : CW → operation command pulse input, CCW → rotation direction pulse input  
([H]: CW rotation, [L]: CCW rotation)

※ 2 Pulse input mode : CW → CW direction rotation pulse input, CCW → CCW direction rotation pulse input

#### • FULL ↔ HALF

※ FULL ↔ HALF switch is to select pulse input mode.

※ If changing resolution while the motor is running, it may cause step-out.

### RUN current setting



※ RUN current is a phase current provided to 5-phase stepper motor.

※ Be sure to set RUN current at the rated current or below.

※ RUN current setting range: 0.5 to 1.5A

※ When changing RUN current, connect CP+ to voltmeter (+) terminal and CP- to voltmeter (-) terminal, then adjust the volume.

※ The formula for phase-current setting is :

$$\text{Setting current(A)} = \frac{\text{CP Input Voltage(V)}}{2}$$



※ Adjust the RUN current in case severe heat generation occurs. Be sure that torque decreasing may occur when adjusting the current.

Note) Be sure to adjust RUN current while motor is running.

### STOP current setting



※ STOP current is a phase current provided to 5-phase stepper motor at standstill.

※ A function to reduce the current in order to suppress the heat generation at motor standstill / STOP current setting range : 25 to 75% of RUN current using VR

※ In case Run current setting value is set to 1.0A and STOP current setting value is set to 50%, STOP current is set to 0.5A.

※ STOP current setting value may have some deviation depending on resistance impedance of motor.

※ STOP current function will be activated when HOLD OFF signal is [L]. When HOLD OFF signal is [H], the function is not activated since the current provided to each phase is cut off.

※ STOP current function will be activated when no operation command pulse is input within 500ms.

Note) Be sure to adjust STOP current while motor is at standstill.

### HOLD OFF function

※ When HOLD OFF input signal is [H], motor excitation is released.

When HOLD OFF input signal is [L], motor excitation is in a normal status.

※ A function used to rotate motor's axis using external force or used for manual positioning.

※ HOLD OFF Input signal [H] and [L] represent photocoupler ON/OFF in a circuit.

※ Please do not use for stopping motor.

# Stepper Motor Driver(1.5A/phase, AC Power)

## Input diagram

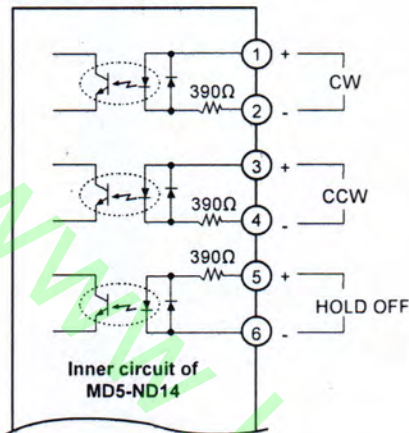

×CW

2 pulse input method(CW direction rotation pulse input)  
1 pulse input method(Operating command pulse input)  
Note) If the power for driving pulse from external is over than +5V, please connect resistor

×CCW

2 pulse input method(CCW direction rotation pulse input)  
1 pulse input method(Rotating direction pulse input)  
→ [H] : CW, [L] : CCW

×HOLD OFF

The control signal for hold off of Motor → [H] : Motor Hold OFF

## Connections

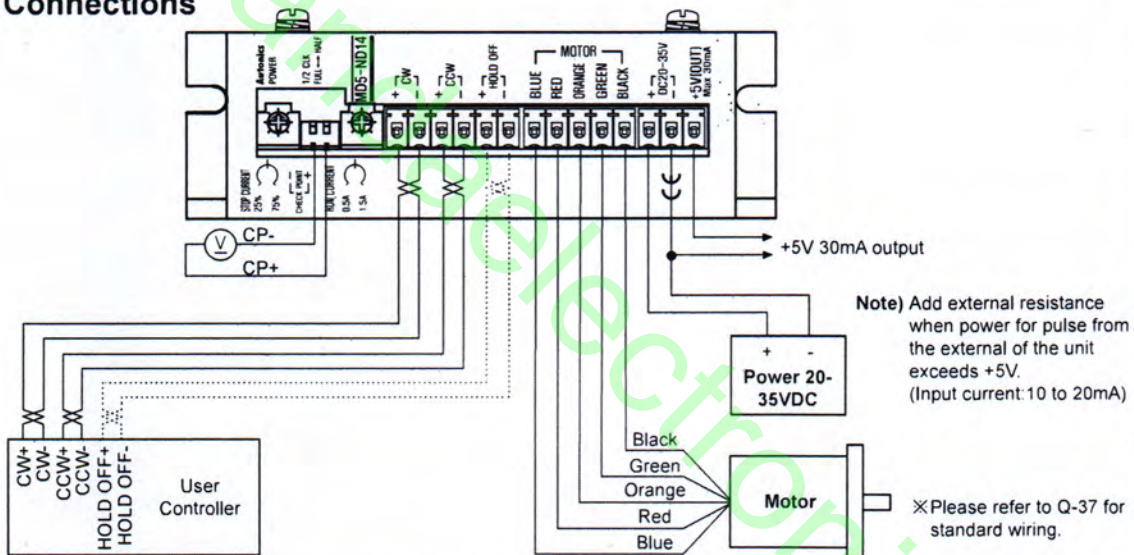

## Dimensions

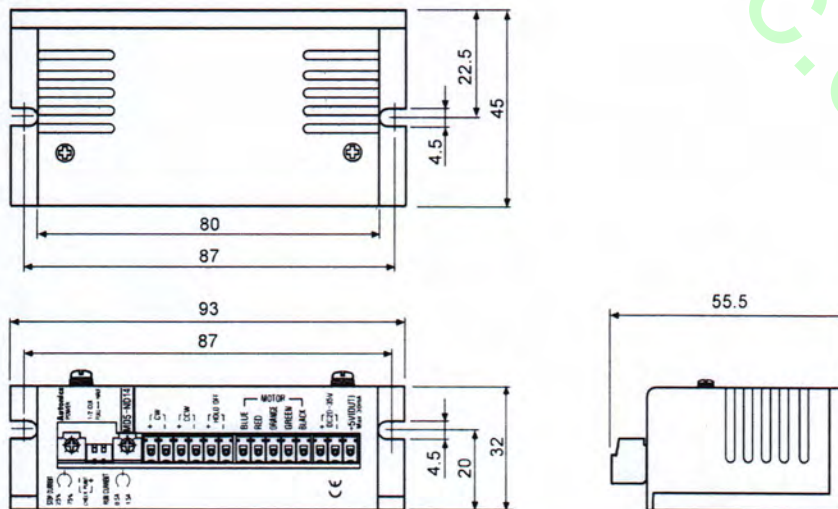

(unit: mm)

- (A) Photo electric sensor
- (B) Fiber optic sensor
- (C) Door/Area sensor
- (D) Proximity sensor
- (E) Pressure sensor
- (F) Rotary encoder
- (G) Connector/Socket
- (H) Temp. controller
- (I) SSR/Power controller
- (J) Counter
- (K) Timer
- (L) Panel meter
- (M) Tacho/Speed/ Pulse meter
- (N) Display unit
- (O) Sensor controller
- (P) Switching mode power supply
- (Q) Stepper motor& Driver&Controller
- (R) Graphic/Logic panel
- (S) Field network device
- (T) Software
- (U) Other