



## Coreless Brushless DC Motor Membrane Air Pump

### TM30A-C/D Series Coreless Brushless DC Motor Membrane Pressure / Vacuum Pump

Model	Pressure Pump (Item Number)	Vacuum Pump (Item Number)	Rated Voltage (Vdc)	No-load Current (A)	Max Pressure (KPa)	Max Vacuum (KPa)	Max Flow (L/min)
TM30A-C	TM30A-C12-P12004	TM30A-C12-V7004	6 / 12 / 24	0.4/0.24/0.15	120	-70	4.5
TM30A-D	TM30A-D12-P12004 (outside controller)	TM30A-D12-V7004 ( outside controller)	6 / 12 / 24	0.4/0.24/0.15	120	-70	4

" P " means pressure pump, " V " means vacuum pump, "6/12/24" means different voltage options

Pump Weight:250g; Pump Size:79mm\*31.2mm\*57.5mm; Inlet&Outlet:OD 4.8mm/ID 2.6mm, hose suggestion:ID 4.0mm

Super silent noise; Materials:pump head Nylon, membrane EPDM / PTFE, valve EPDM / FPM

Motor type and code:"C":Coreless brushless DC motor with dual ball bearings (long lifetime 15,000hours) "D": Coreless brushless DC motor with dual ball bearings + outside controller (long lifetime 15,000hours); pump with outside controller can realize functions of speed adjustment, brake, instant starting work ; inner controller is no additional functions.

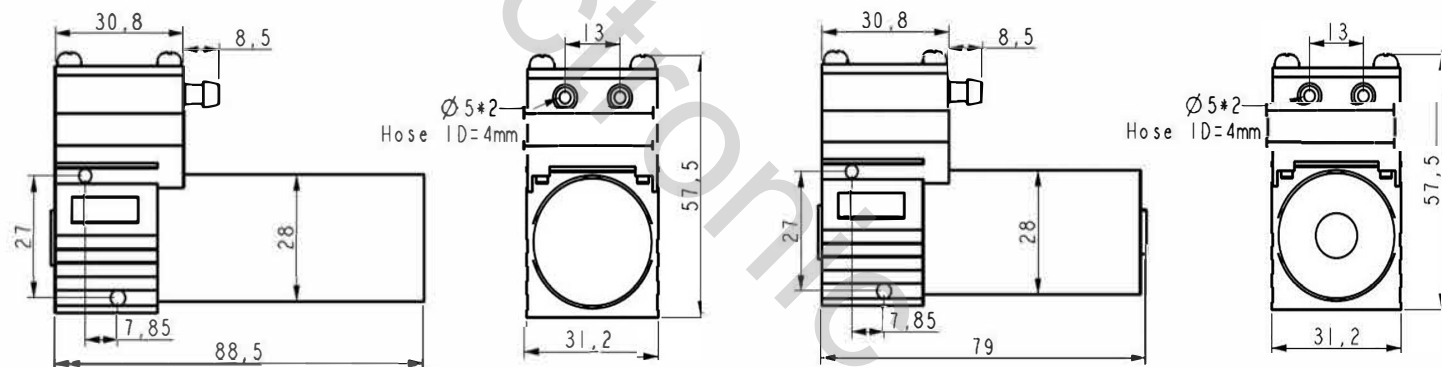
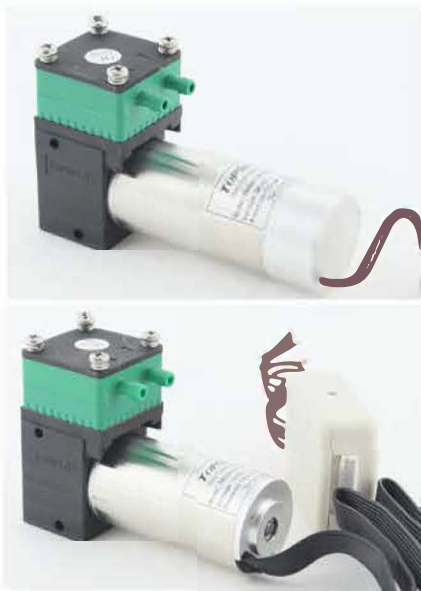

C- inside controller type

D- outside controller type