

SR2-Plus

2 Phase Step Motor Drive



User Manual
Rev. 1.0

AMP & MOONS' Automation

Contents

1 Introduction	3
1.1 Overview.....	3
1.2 Features.....	3
1.3 Block diagram.....	4
2 Mounting the Drive	4
3 Connections	5
3.1 Connector Diagram.....	5
3.2 Connecting to the Power Supply	5
3.3 Connecting to a Motor	6
3.4 Connecting the I/O.....	6
3.4.1 Step & Direction Inputs.....	6
3.4.2 EN input.....	6
3.4.3 Fault Output.....	7
4 Switch Selecting	8
4.1 Running Current.....	8
4.2 Idle Current.....	8
4.3 Microstepping	9
4.4 Self test.....	9
4.5 Command Signal Smoothing.....	10
4.6 Load Inertia.....	10
4.7 Digital Signal Filter.....	10
5 Motor Selection	11
5.1 Recommended Motors	11
6 LED Error Codes	13
7 Reference Materials	13
7.1 Mechanical Outline	13
7.2 Specifications.....	14
7.2.1 Electrical Specifications.....	14
7.2.2 Environmental Specifications	14
7.3 Torque Curves	15
8 Contacting MOONS'	17

1 Introduction

Thank you for selecting the MOONS' SR2-Plus Step Motor Drive. We hope our commitment to performance, quality and economy will make a successful motion control project.

1.1 Overview

The SR series drives are cost-effective, high performance 2 phase step drives. The design is based on advanced digital current control technology, and features high torque, low noise, and low vibration. The running current, microstep resolution and other parameters are switch selectable.

1.2 Features

- Power Supply - operates from a 12 to 48 volt DC power supply
- Output Power - switch selectable, 8 settings, maximum 2.2 amps peak
- Current Control - advanced digital current control provides excellent high speed torque
- Microstep Resolution - switch selectable, 16 settings: 200, 400, 800, 1600, 3200, 6400, 12800, 25600, 1000, 2000, 4000, 5000, 8000, 10000, 20000, 25000 step/rev
- Speed Range - speeds up to 3000 rpm
- Anti Resonance - raises the system-damping ratio to eliminate midrange instability and allow stable operation throughout the speed range of the motor.
- Auto Setup - measures motor parameters and configures motor current control and anti-resonance gain settings
- Microstep Emulation - performs high resolution stepping by synthesizing coarse steps into fine micro-steps
- Protection - SR2-Plus drive has Over-Voltage, Under-Voltage, Over-Current, Motor-Short (Phase to Phase, Phase to Ground), Over-Temperature and Motor-Open protection features.
- Control Modes - Step & Direction or CW/CCW pulse
- Input Digital Filters - 150 kHz or 2 MHz digital filter for high speed inputs
- Idle Current - switch selectable for 50% or 90% idle running current reduction 1 second after the motor stops
- Self Test - switch selectable, the drive will perform a 2 rev, 1 rps, CW/CCW move test
- Signal Smoothing - switch selectable, firmware configurable filtering removes spectral components from the command sequence, reducing jerk, limiting excitation of system resonance

1.3 Block diagram

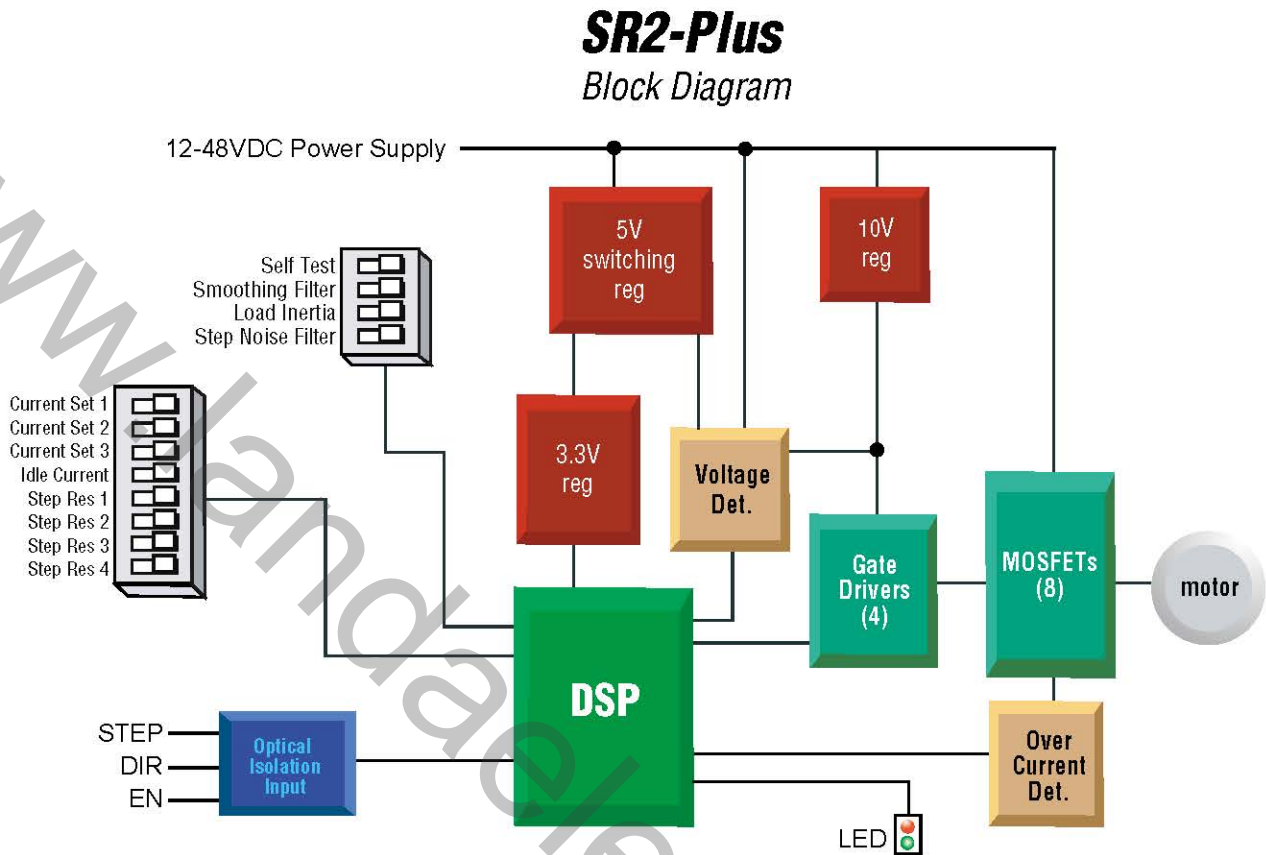

2 Mounting the Drive

The SR2-Plus Step Drive can be mounted on the wide or the narrow side of the chassis. If it is mounted on the wide side, M3 screws should be used through the four corner holes. For narrow side mounting applications, M3 screws can be used in the two side holes.

The amplifiers in the drive generate heat. To operate the drive continuously at maximum power, forced air cooling, as from a fan, should be provided.

Never use the drive in a space where there is no air flow or where other devices can cause the surrounding air to be more than 40 °C. Never put the drive where it can get wet or where metal particles can fall into it.

3 Connections

To use the SR2-Plus Step Drive, the following items are needed:

- A power supply (12 - 48 VDC)
- Pulse & Direction signal
- A compatible step motor

3.1 Connector Diagram



3.2 Connecting to the Power Supply

If the power supply does not have a fuse on the output or some kind of short circuit current limiting device, a fast acting fuse is required. A 3 amp fast acting fuse should be installed in line with the "+" power supply lead.

Connect the motor power supply "+" terminal to the drive terminal labeled "V+". Connect the power supply "-" to the drive terminal labeled "V-".

Be careful not to reverse the wires.

3.3 Connecting to a Motor

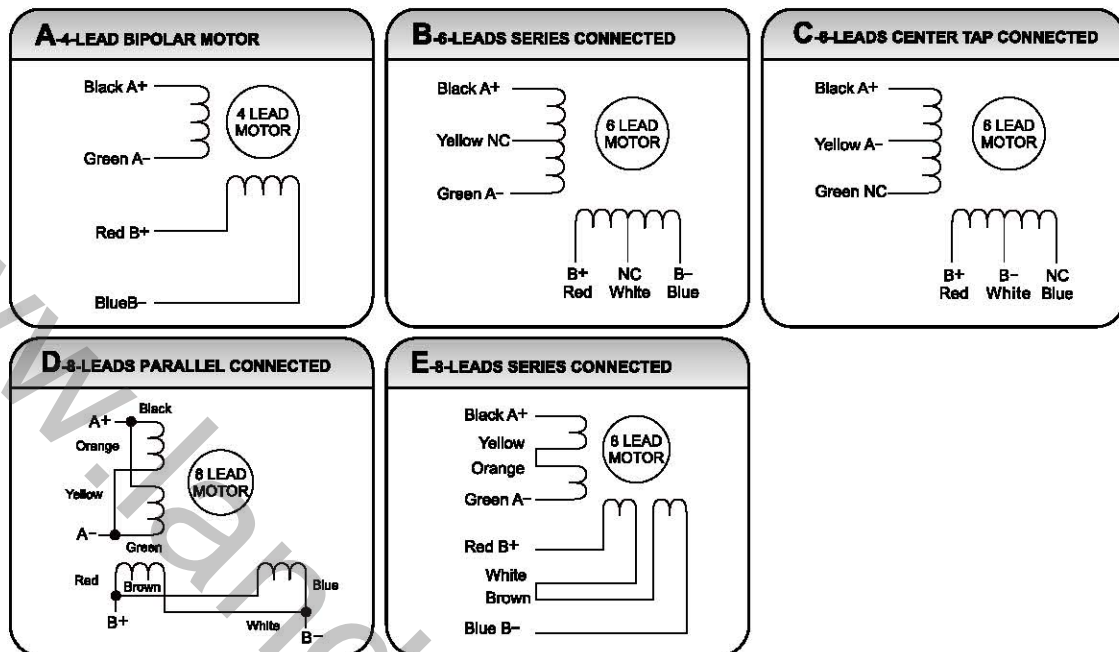

3.4 Connecting the I/O

3.4.1 Step & Direction Inputs

The SR2-Plus Step Drive has two high speed optically isolated inputs called STEP and DIR that accept 5 to 24 volt single-ended(sinking output) signals, up to 2MHz. The maximum voltage that can be applied to the input is 28V.

The motor executes one step with the falling edge of the STEP signal.

The direction of rotation is controlled by the DIR signal level. A high level signal (High Level) will result in clockwise rotation, and a low level signal (Low Level) will result in counterclockwise rotation.

3.4.2 EN input

The EN input enables or disables the drive amplifier. It is an optically isolated input that accepts a 5 to 24 volt single-ended(sinking output) signals. The maximum voltage that can be applied to the input is 28V.

When EN input is closed, the drive amplifier is deactivated. All the MOSFETs will shut down, and the motor will be free. When EN input is open, the drive is activated.

When the drive has encountered an error and the fault is removed from system, a falling signal into the EN input will reset the error status and activate the drive amplifier again.

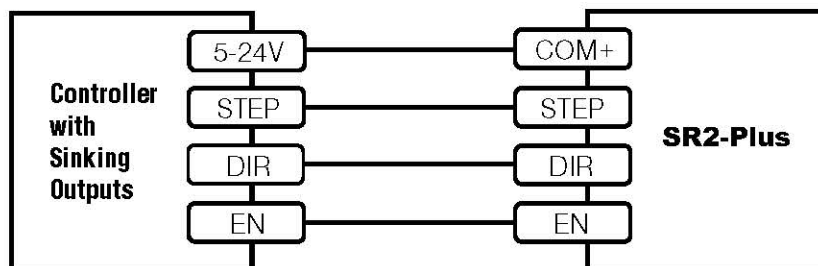

3.4.3 Fault Output

The FAULT Output is optically isolated. The maximum collector current is 100mA, and the maximum collector to emitter voltage is 30 volts. The output can be wired to sink or source current.

When drive is working normally, the output is open. When the drive encounters an error, the output closes.

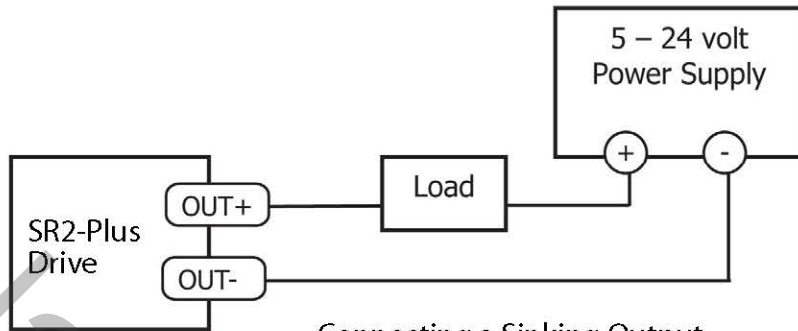

Connecting a Sinking Output

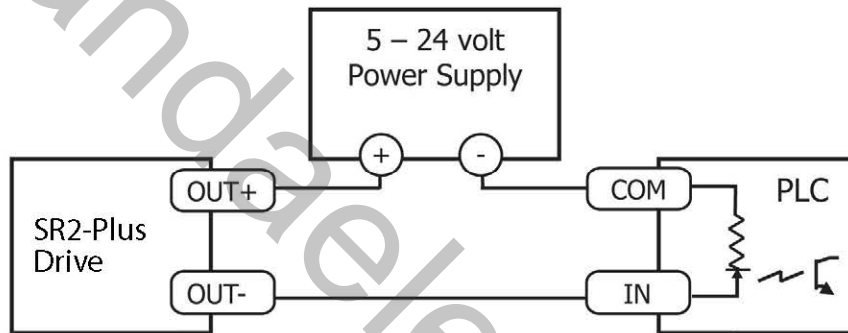

Connecting a Sourcing Output

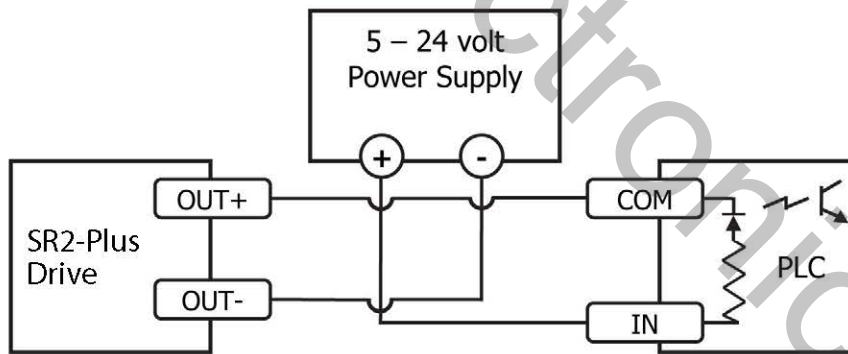

Connecting Sourcing Output

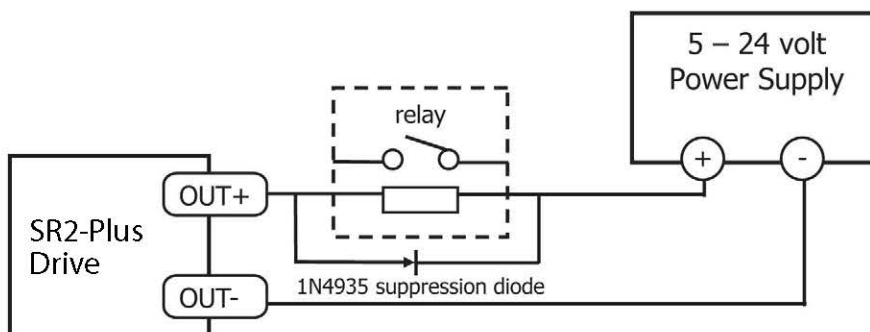

Driving a Relay

4 Switch Selecting

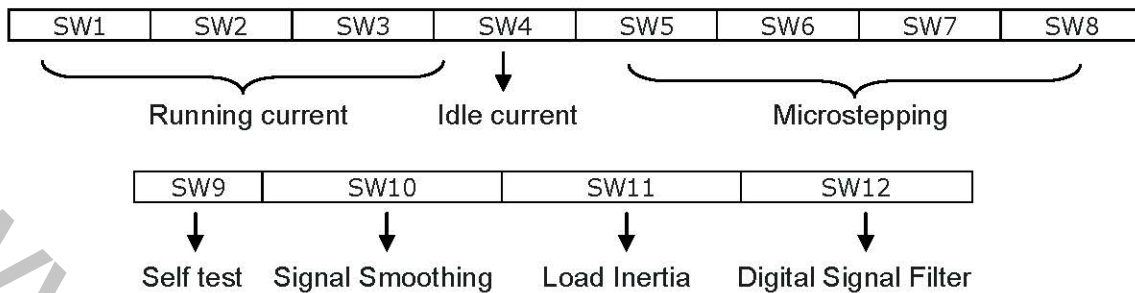

4.1 Running Current

The output current of the SR2-Plus Step Drive is set by the SW1, SW2, and SW3 switches and can be changed as necessary. There are 8 settings available according to the ON/OFF combination of the switches.

Peak	SW1	SW2	SW3
0.3A	ON	ON	ON
0.5A	OFF	ON	ON
0.7A	ON	OFF	ON
1.0A	OFF	OFF	ON
1.3A	ON	ON	OFF
1.6A	OFF	ON	OFF
1.9A	ON	OFF	OFF
2.2A	OFF	OFF	OFF

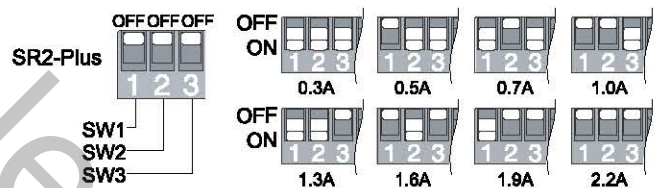

4.2 Idle Current

The running current of the SR2-Plus drive is automatically reduced whenever the motor hasn't moved for 1 second. Setting the SW4 switch to ON reduces the current to 50% of its running value. Setting this switch to OFF maintains 90% of the running current. This 90% setting is useful when a high holding torque is required. To minimize motor and drive heating it is highly recommended that the idle current reduction feature be set to 50% unless the application requires the higher setting.

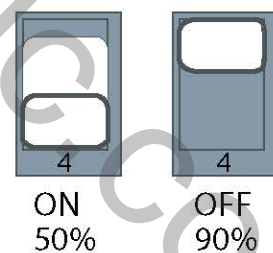

4.3 Microstepping

The microstep resolution is set by the SW5, SW6, SW7, and SW8 switches. There are 16 settings.

Microstep(step/rev)	SW5	SW6	SW7	SW8
200	ON	ON	ON	ON
400	OFF	ON	ON	ON
800	ON	OFF	ON	ON
1600	OFF	OFF	ON	ON
3200	ON	ON	OFF	ON
6400	OFF	ON	OFF	ON
12800	ON	OFF	OFF	ON
25600	OFF	OFF	OFF	ON
1000	ON	ON	ON	OFF
2000	OFF	ON	ON	OFF
4000	ON	OFF	ON	OFF
5000	OFF	OFF	ON	OFF
8000	ON	ON	OFF	OFF
10000	OFF	ON	OFF	OFF
20000	ON	OFF	OFF	OFF
25000	OFF	OFF	OFF	OFF

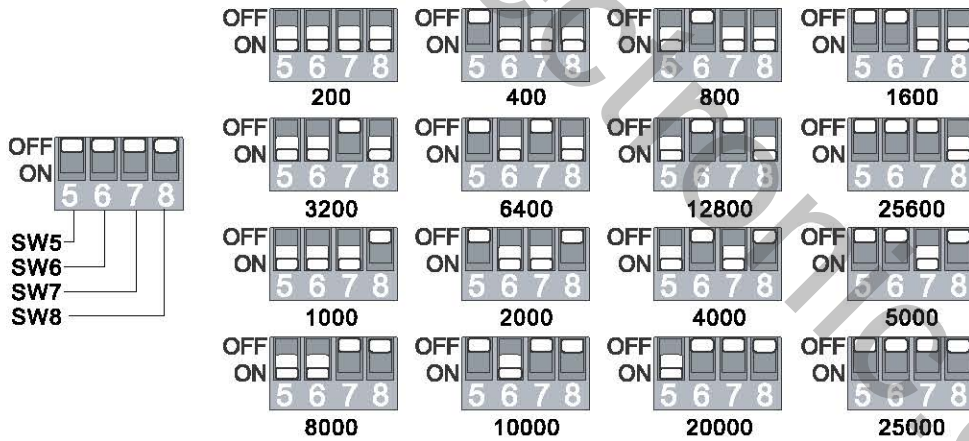

4.4 Self test

Setting switch SW9 to ON after the drive is powered up will cause the drive to perform a self test move of 2 revolutions both CW and CCW at 1rps. Setting switch SW9 to OFF will disable this feature.

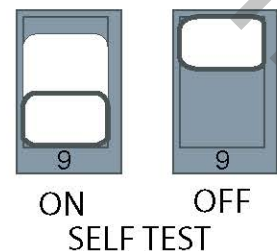

4.5 Command Signal Smoothing

Setting switch SW10 to ON selects this function; setting it to OFF will disable it. Command signal smoothing can soften the effect of immediate changes in velocity and direction, making the motion of the motor less jerky. An added advantage is that it reduces wear on mechanical components. This function can cause a short delay in following the control signal, and should be used with that in mind.

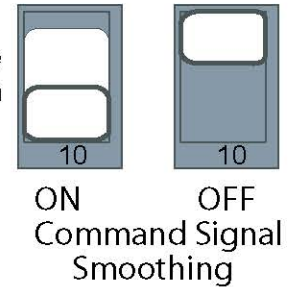

4.6 Load Inertia

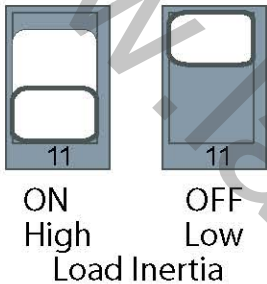

Switch SW11 selects the load inertia. Set it to ON for high inertia applications and to OFF for low inertia applications. The load inertia selection can help the SR2-Plus drive to calculate the current control parameter, which is used in Anti-Resonance. If the load inertia is close to that of the motor rotor, select the low (OFF) setting. If the load inertia is higher than that of the motor rotor, select the high (ON) setting.

4.7 Digital Signal Filter

Switch SW12 sets the digital signal filter. The STEP and DIR signal inputs have built-in digital filters and this setting will reduce external noise. If the system works on the low microstep, select the 150 KHz (ON) setting. If the system works on the high microstep, select the 2 MHz (OFF) setting.

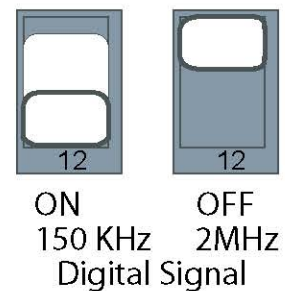

5 Motor Selection

The SR2-Plus Step Drive can drive all kinds of two-phase step motors. Several MOONS' motors are recommended below that will cover most applications and provide good performance.

5.1 Recommended Motors

11HS Series 1.8°

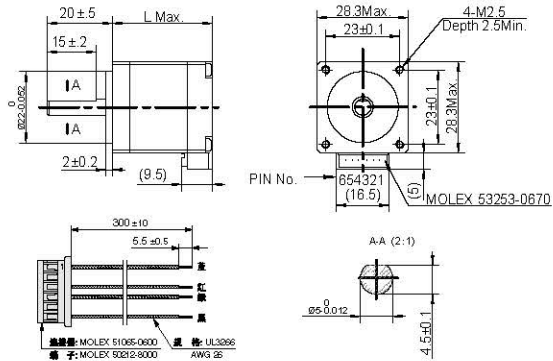

Parameters

PART#	SHAFT	WIRING DIAG	#OF LEADS	LENGTH	HOLDING TORQUE	CURRENT	OHMS	ROTOR INERTIA	MOTOR WEIGHT
				mm	N·m	A/PHASE	Ω/PHASE	g·cm ²	Kg
11HS1008-07	Single Shaft	A	4	31.0	0.05	1.6	2.5	9.0	0.1
11HS3007-02	Single Shaft			40.0	0.08	1.6	1.7	12.0	0.15
11HS5008-01	Single Shaft			51.0	0.12	1.6	3.5	18.0	0.2

14HY Series 1.8°

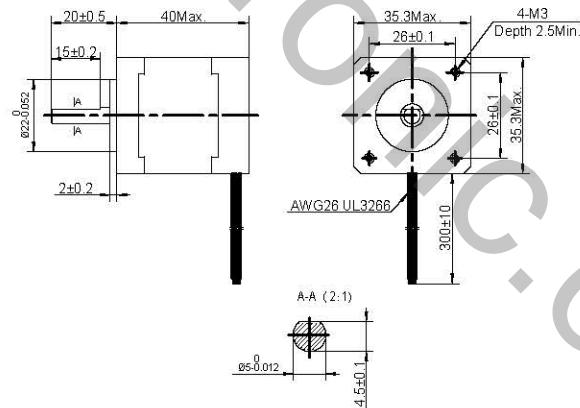

Parameters

PART#	SHAFT	WIRING DIAG	#OF LEADS	LENGTH	HOLDING TORQUE	CURRENT	OHMS	ROTOR INERTIA	MOTOR WEIGHT
				mm	N·m	A/PHASE	Ω/PHASE	g·cm ²	Kg
14HYB401-03	Single Shaft	A	4	40.0	0.2	1.0	4.3	20.0	0.21

6 LED Error Codes

The SR2-Plus Step Drive has one bicolor (red/green) LED to indicate status. When the motor is enabled, the green LED flashes slowly. When the green LED is solid, the motor is disabled. If the red LED flashes, an error has occurred. Errors are indicated by a combination of red and green flashes as follows:

	Code	Error
●	Solid green	Motor disabled
●●	Flashing green	Motor enabled
●●●●●	3 red, 1 green	Over temperature
●●●●●●	3 red, 2 green	Bad internal voltage
●●●●●●●	4 red, 1 green	Over voltage
●●●●●●●●	4 red, 2 green	Under voltage
●●●●●●●●●	5 red, 1 green	Over current/short circuit
●●●●●●●●●●	6 red, 1 green	Open motor winding

7 Reference Materials

7.1 Mechanical Outline

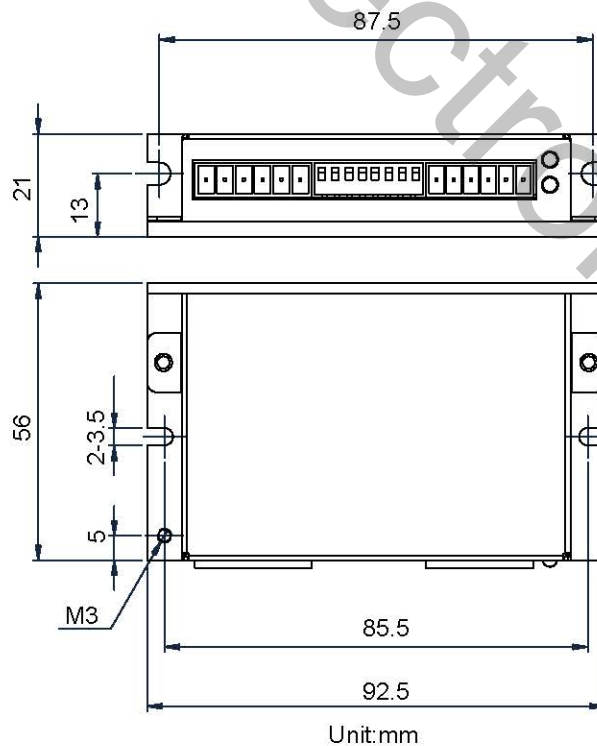

7.2 Specifications

7.2.1 Electrical Specifications

Parameter	Min.	Typ.	Max.	Unit
Power Supply	12	-	48	VDC
Output Current (Peak)	0.3	-	2.2	Amps
Step Frequency	2	-	2M	Hz
STEP Minimum Pulse Width	250	-	-	ns
DIR Minimum Pulse Width	62.5	-	-	us
Under Voltage Protection	-	10	-	VDC
Over Voltage Protection	-	52	-	VDC
Over Temperature	-	85°C	-	-
Input signal Voltage	4.0	-	28	VDC
Driver Initialization time	-	-	2.5	S
OUT minimum output current	-	-	100	mA
OUT maximum voltage	-	-	30	VDC

7.2.2 Environmental Specifications

Heat Sinking Method	Natural cooling or fan-forced cooling
Surrounding Air Conditions	Avoid dust, oily mist and corrosive air
Operating Temperature	0 - 40°C (32 - 104°F)
Maximum Ambient Humidity	90% non-condensing
Shock	5.9m/s ² maximum
Storage Temperature	-10 - 70°C (14 - 158°F)

7.3 Torque Curves

11HS1008

Drive: SR2-Plus
 Microstep: 20000 steps/rev
 Current: 1.6A (Peak)

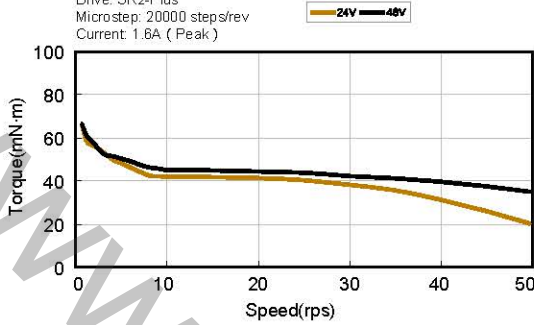

11HS3007

Drive: SR2-Plus
 Microstep: 20000 steps/rev
 Current: 1.6A (Peak)

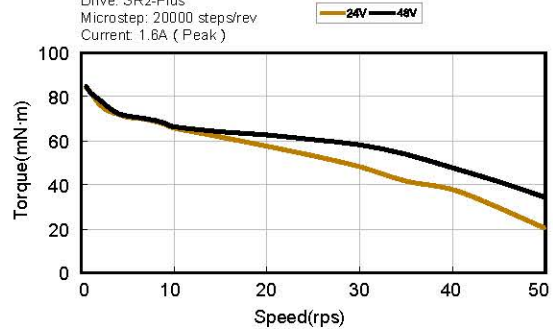

11HS5008

Drive: SR2-Plus
 Microstep: 20000 steps/rev
 Current: 1.6A (Peak)

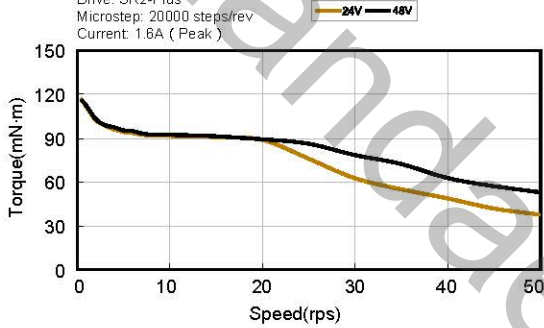

14HYB401

Drive: SR2-Plus
 Microstep: 20000 steps/rev
 Current: 1.0A (Peak)

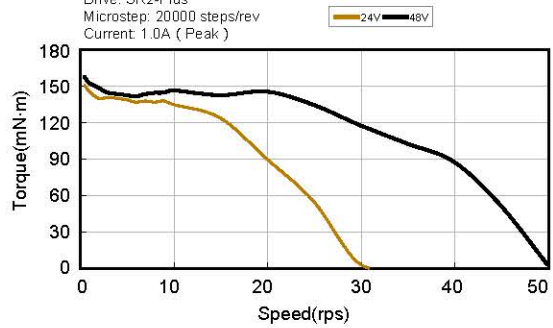

17HD4452N

Drive: SR2-Plus
 Microstep: 20000 steps/rev
 Current: 1.8A (Peak)

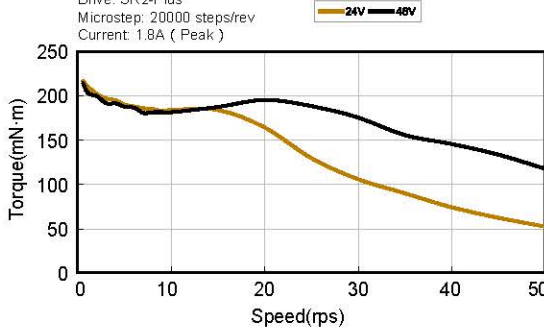

17HD2438N

Drive: SR2-Plus
 Microstep: 20000 steps/rev
 Current: 1.8A (Peak)

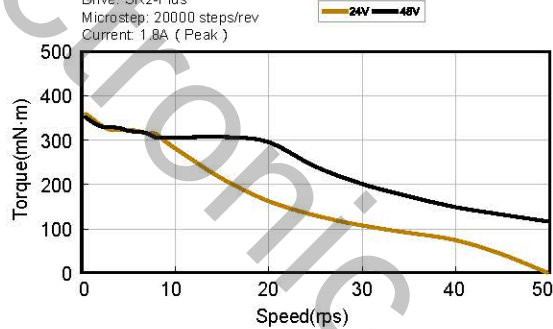

17HD6426N

Drive: SR2-Plus
 Microstep: 20000 steps/rev
 Current: 1.8A (Peak)

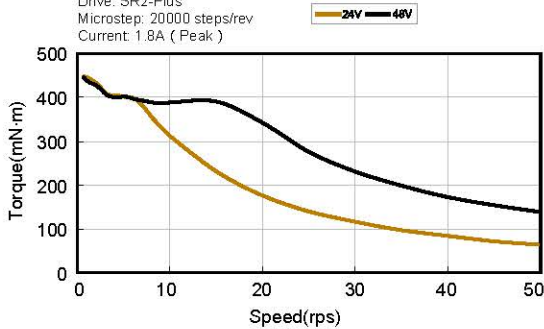

23HS0420

Drive: SR2-Plus
 Microstep: 20000 steps/rev
 Current: 2.2A (Peak)

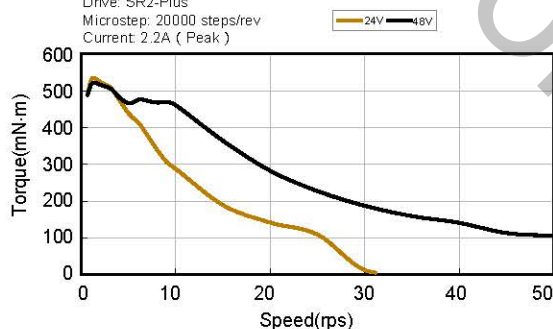

23HS2449

Drive: SR2-Plus
Microstep: 20000 steps/rev
Current: 2.2A (Peak)

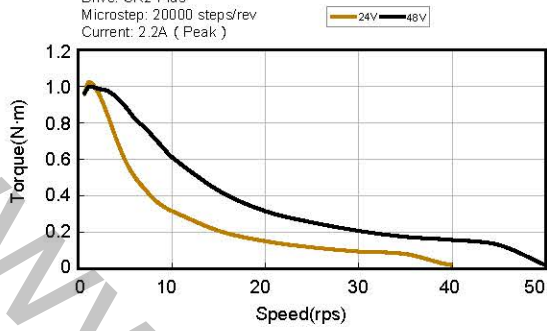

23HS3454

Drive: SR2-Plus
Microstep: 20000 steps/rev
Current: 2.2A (Peak)

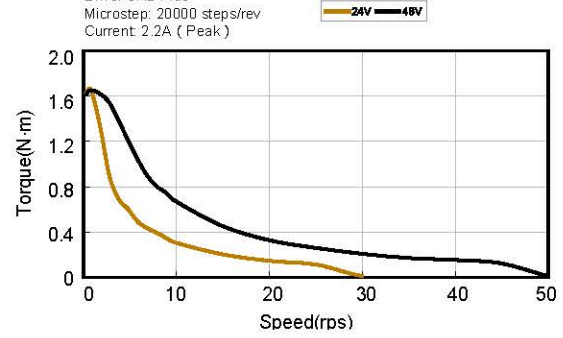

www.landaelectronic.com