

## 1.8° 20mm High Torque Hybrid Stepper Motor

Item	Specifications
Step Angle	1.8°
Step Angle Accuracy	±5% (full step, no load)
Resistance Accuracy	±10%
Inductance Accuracy	±20%
Temperature Rise	80° C Max. (rated current, 2 phase on)
Ambient Temperature	-20°C ~ +50°C
Insulation Resistance	100MΩMin., 500VDC
Dielectric Strength	500VAC for one minute
Shaft Radial Play	0.02Max. (450 g-load)
Shaft Axial Play	0.08Max. (450 g-load)
Max. radial force	20N
Max. axial force	2N

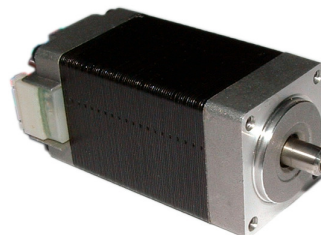

### Specifications

Model No	Rated Voltage (V)	Current /Phase (A)	Resistance /Phase (Ω)	Inductance /Phase (mH)	Holding Torque (g.cm)	# of Leads	Rotor Inertia (kg·m <sup>2</sup> )	Shaft	Motor Length (mm)	Weight (kg)
FL20STH30-0604A	3.9	0.6	6.5	1.7	180	4	2.0x10 <sup>-7</sup>	Single	30	0.06
FL20STH33-0604A	3.9	0.6	6.5	1.7	180	4	2.0x10 <sup>-7</sup>	Single	33	0.06
FL20STH33-0604B	3.9	0.6	6.5	1.7	180	4	2.0x10 <sup>-7</sup>	Double	33	0.06
FL20STH42-0804B	4.32	0.8	5.4	1.5	300	4	3.6x10 <sup>-7</sup>	Double	42	0.10
FL20STH42-0804A	4.32	0.8	5.4	1.5	300	4	3.6x10 <sup>-7</sup>	Single	42	0.10

### Dimension

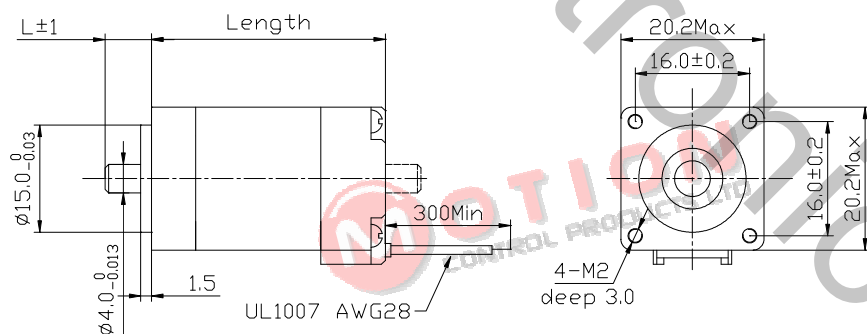

### Wiring Diagram

