



hybrid stepping motor **MOONS'**



23HS Series

Key Features

- High Torque
- High Accuracy
- Smooth Movement

Uni-polar

Model Number	Resistance per Phase	Inductance per Phase	Rated Current	Holding Torque	Detent Torque		Rotor Inertia	Insulation Class
	ohm	mH	A	Nm	mNm	oz-in	g.cm ²	°C
23HS5604	1	2	4.3	2	120	17.00	750	130

DIMENSION

DIMENSION (UNIT : mm)

Model Number	L	Mass
	mm (in.)	kg (lb.)
23HS5**	111 (4.37)	1.50 (3.30)

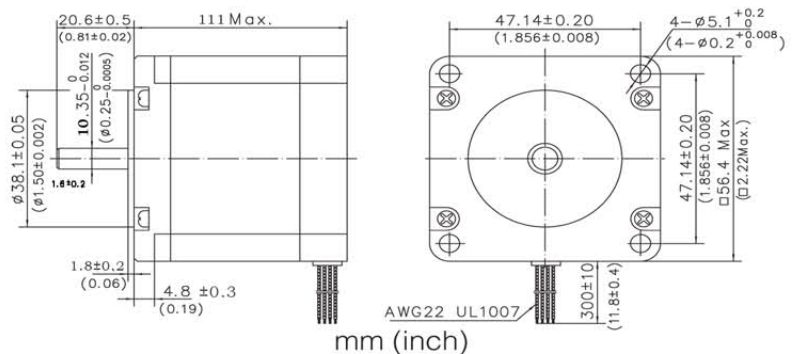

WIRING DIAGRAM AND DRIVING

Exciting Sequence vs. Direction of Rotation

STEP	A	B	C	D	H	CCW
1	-	-	-	+	+	↑
2	-	-	+	+	+	
3	+	+	+	-	-	
4	+	+	-	-	-	

CCW

Clockwise view from mounting side

Wiring Diagram

